

Cencorp 1300 SR

Depaneling

New Cencorp Off-line Router

Cencorp, market leaders in the supply of routers for over 30 years have introduced the next generation of depaneling systems in the form of the 1300 SR off-line router.

This new stand-alone router's modular concept allows multiple configurations to match process requirements and its new design allows better access to the machine for operator convenience and a larger routing area enabling the use of larger panel sizes. The Cencorp 1300 SR offers excellent price performance and is simple, flexible and meets most production requirements.

Robust and Accurate

The Cencorp 1300 SR's robust platform enables extremely high accuracy production and its modular concept allows Cencorp to adapt the machine to meet your individual needs, maximizing return on investment. This system has the capability and reliability demanded by today's competitive market.

The 1300 SR accommodates both v-scored and prerouted panel designs and automatic tooling changes combined with automatic product verification make this system a perfect fit for high mix environments.

Two different configurations are available within the same platform, the rotary table with very short load/unload times for continuous production or sliding table machine and any upgrades can be completed on-site. The Cencorp 1300 SR is ideal for low stress and accurate PCB separation providing a superior edge finish.

Ergonomic and User Friendly Interface

Both the rotary and sliding tables are available with a unique operator load/unload station that presents the product directly in front of the operator, thereby reducing operator fatigue and physical stress. The

Cencorp control software with graphical user friendly interface runs on an industrial PC with Windows® operating software.



Cencorp 1300 SR

Technical Data

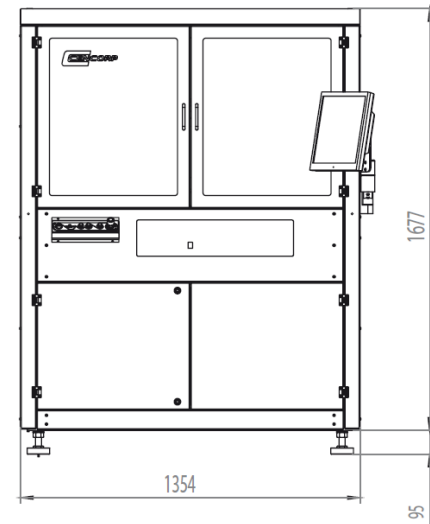
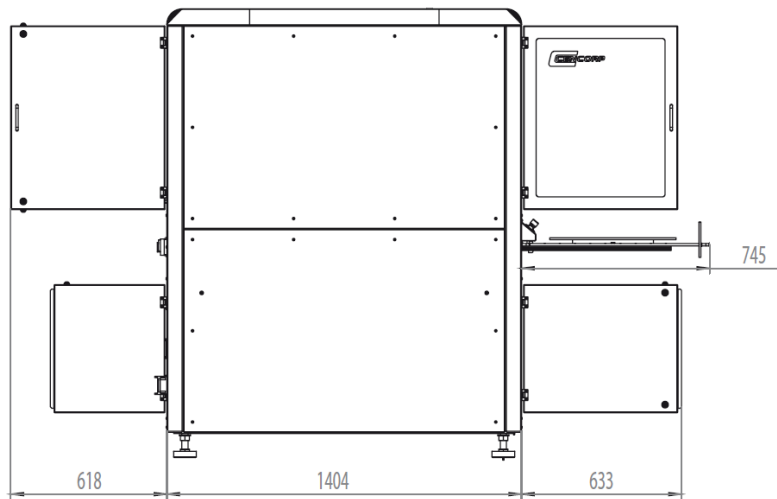

Machine Dimensions

Width: 1300 mm (51.2")
 Depth: 1440 mm (56.7")
 Height: 1733 mm (69.8")
 Approx. weight: 1000 kilos (2200 lbs.)

Gantry

Linear motors X and Y axes
 Repeatability: ± 0.02 mm
 Configuration: X, Y, Z

Board Handling

Sliding table: Max panel size 610 mm x 559 mm (24" x 22")
 Rotary table: Max panel size 350 mm x 450 mm (13.78" x 17.72")
 Panel thickness : 45 mm spindle: Up to 4 mm (0.16")
 Max component height: 10 mm (0.39"), Bottom (tooling) side: 50.8 mm (2"), Top (router) side: 10 mm (0.39")
 Load height: 800/900 mm (31.5/35")

Utilities

Voltage: 208-220, 3-phase, 60 Hz, 20 Amps
 380-400, 3-phase, 50 Hz, 16 Amps
 Pressure: 5.5 bar (80 PSI) clean, dry air
 Flow: 85 l/min (3 SCFM)

Spindle Motor

Type: 45 mm ball-bearing spindle
 Max speed: Variable up to 50,000 RPM
 Cooling: Air cooled
 Router bit: Shank size 3.175 mm (1/8")
 Tool change: Automatic / Manual option
 Routing speed: Up to 40 mm /sec
 Slew speed: Up to 1500 mm /sec

Control

Cencorp 1300 SR control software
 Industrial computer
 Windows
 Network connection: Optional
 Touch Screen Monitor

Standard Features

Broken Bit Detection
 Ergonomic Operator Load / Unload
 CE Certification

Programming

Camera-Assisted Teaching System (CATS)
 Manually or automatically step through program to verify the program before running production.

Software Features

Event Log
 Diagnostic Tools
 Tool Life Tracking
 Vacuum Bag Life Tracking
 Multi-Level Password Protection

Options

Barcode Program Verification Software
 Automatic Fixture Verification
 Tall Component Clearance 20 mm
 Tool change: Automatic
 Routing speed: Up to 40 mm /sec
 Slew speed: Up to 1500 mm /sec

External vacuum system

Nilfisk: Optional
 Ruwac: Optional
 Dust flow control: Optional